

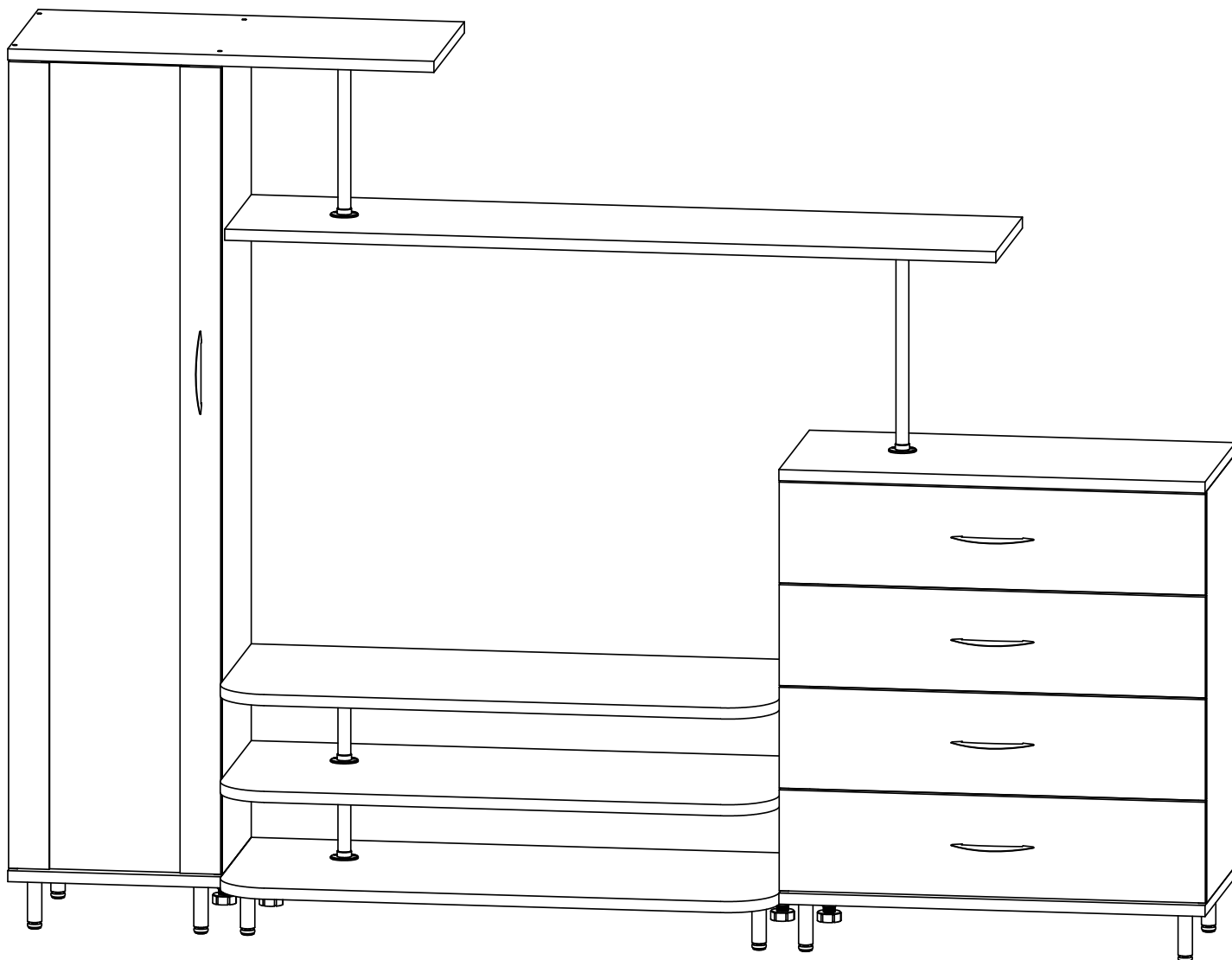

**EAC**

## ИНСТРУКЦИЯ ПО СБОРКЕ

### Набор корпусной мебели «Грация -03»



ОАО «ЖЛОБИНМЕБЕЛЬ»

247210 Беларусь. Гомельская обл.,

г. Жлобин, ул. Подъездная, 2

Тел./факс гарантийного отдела (+37502334) 3-00-03 e.mail:Otk.zhlobin.mail.ru



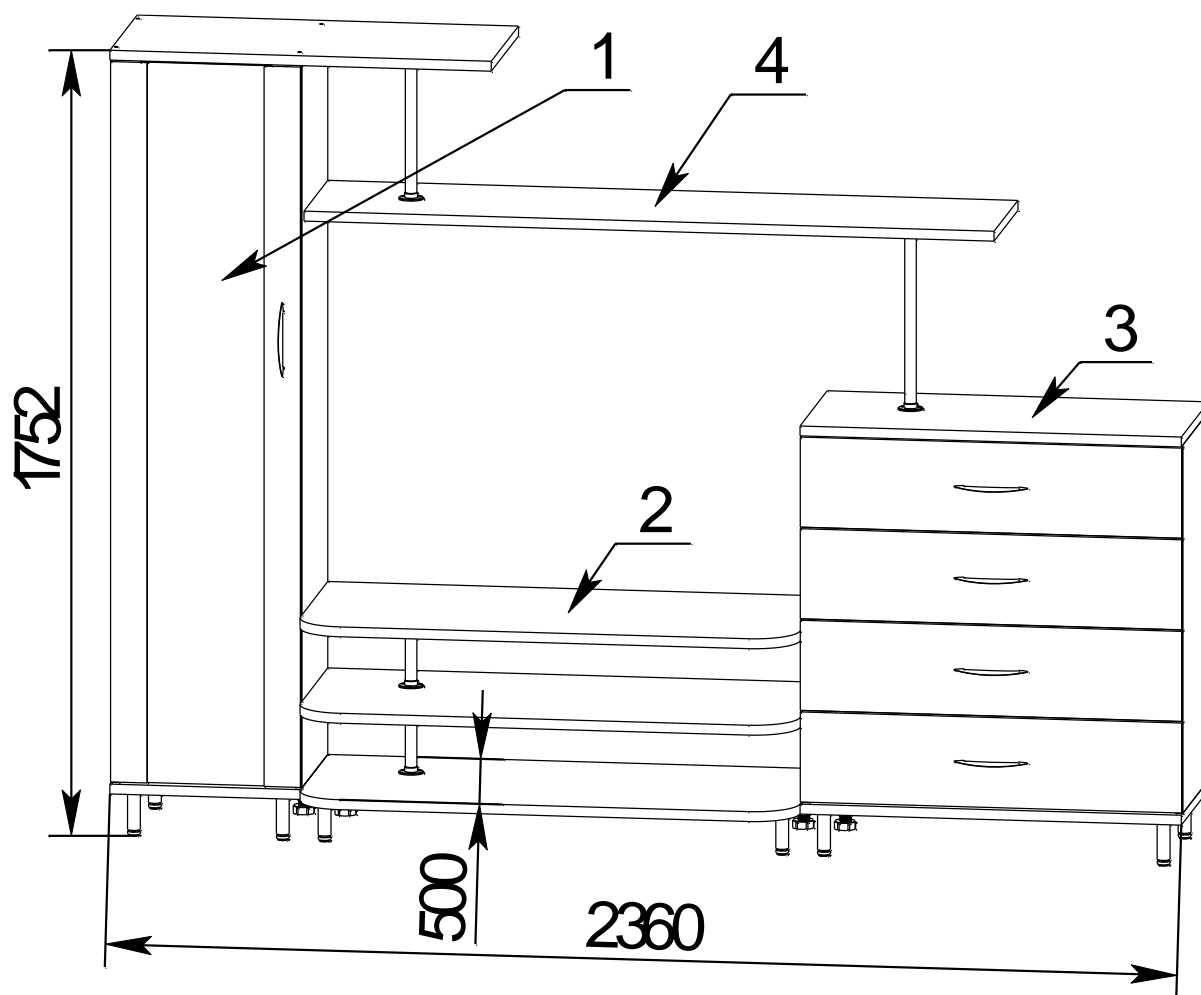
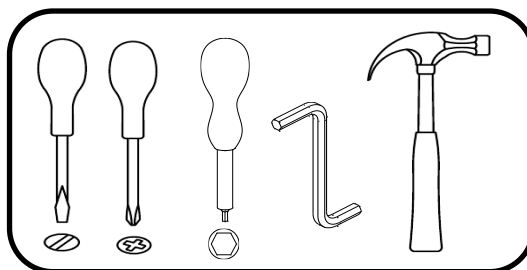

Тел./факс сектор сбыта (+37502334) 3-17-01

[www.laguna.by](http://www.laguna.by)

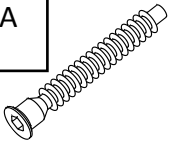
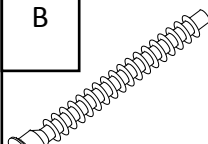
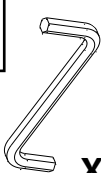
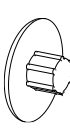
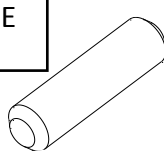

*Комплектность набора*

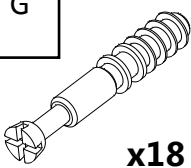
№	Наименование изделия	Кол-во в наборе
1	Шкаф для книг 1	1
3	Комод	1
2	Тумба для телерадиоаппаратуры	1
4	Полка	1

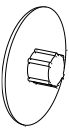
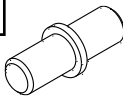
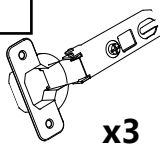
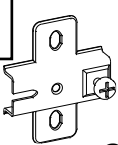
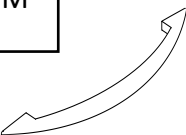
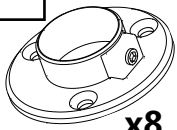
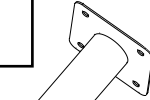
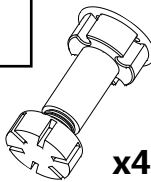
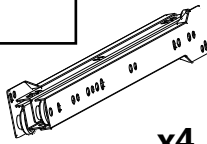
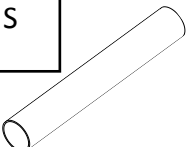
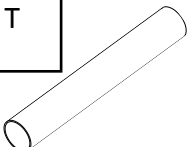
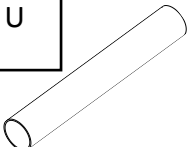
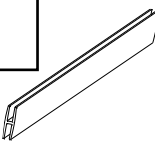
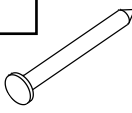
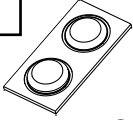
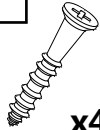
A		B		C		D		E		F	<b>4x13</b>	
<b>7x50 x18</b>		<b>7x70 x12</b>		<b>X1</b>		<b>x10</b>		<b>x54</b>		 <b>x114</b>		
G		H		I		JK		K		L		
<b>x18</b>		<b>x18</b>		<b>x8</b>		<b>x12</b>		<b>x3</b>		<b>x3</b>		
M		N	<b>4x18</b>	O		P		Q		R		
<b>x5</b>		<b>10</b>		<b>x8</b>		<b>x8</b>		<b>x4</b>		<b>x4</b>		
S		T		U		V		W		X		
<b>l=165 x2</b>		<b>l=330 x1</b>		<b>l=410 x1</b>		<b>l=815 x1</b>		<b>x65</b>		<b>x8</b>		
Y												
<b>3x18</b>												
 <b>x48</b>												

## 1. Сборка Шкаф для книг

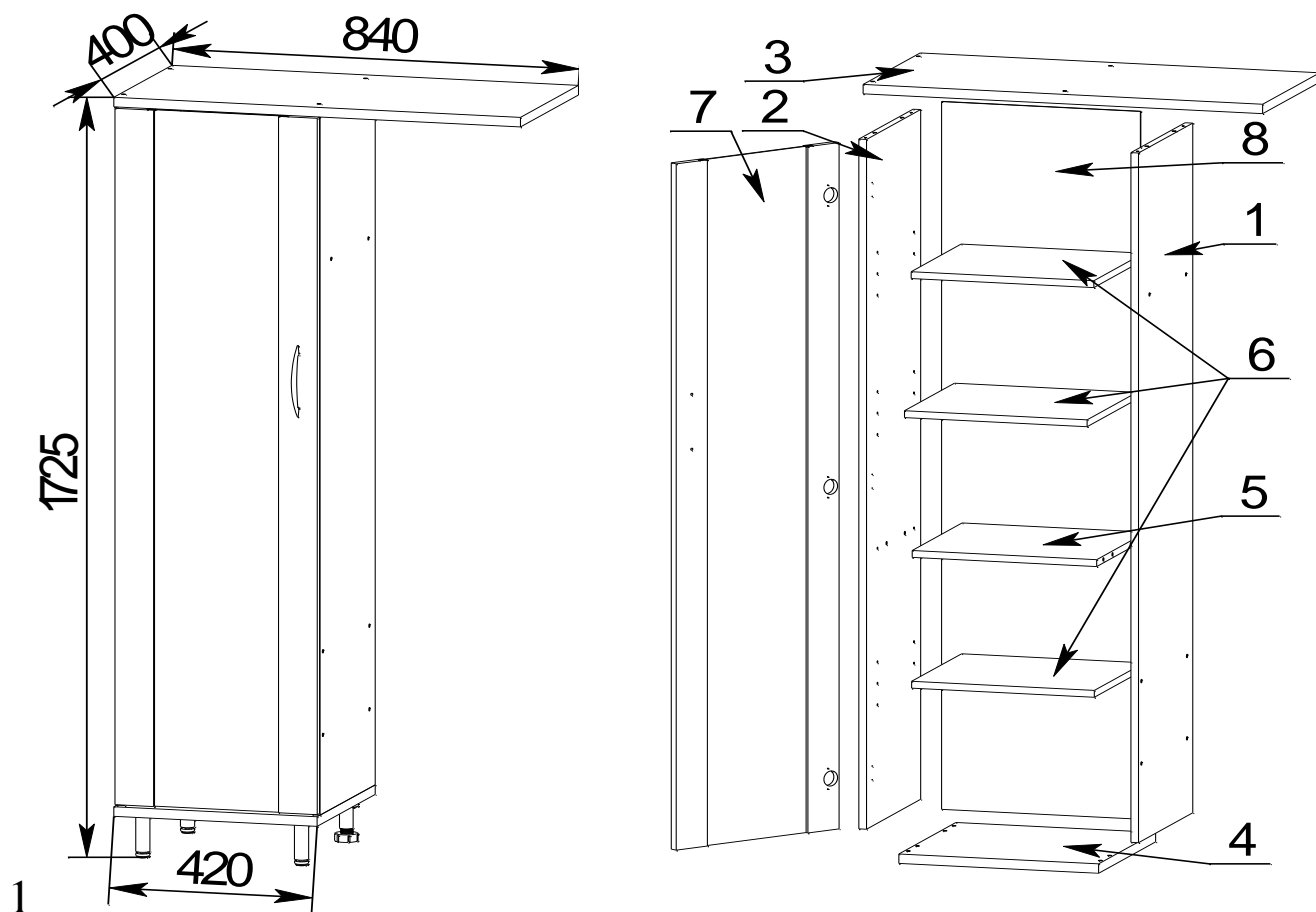

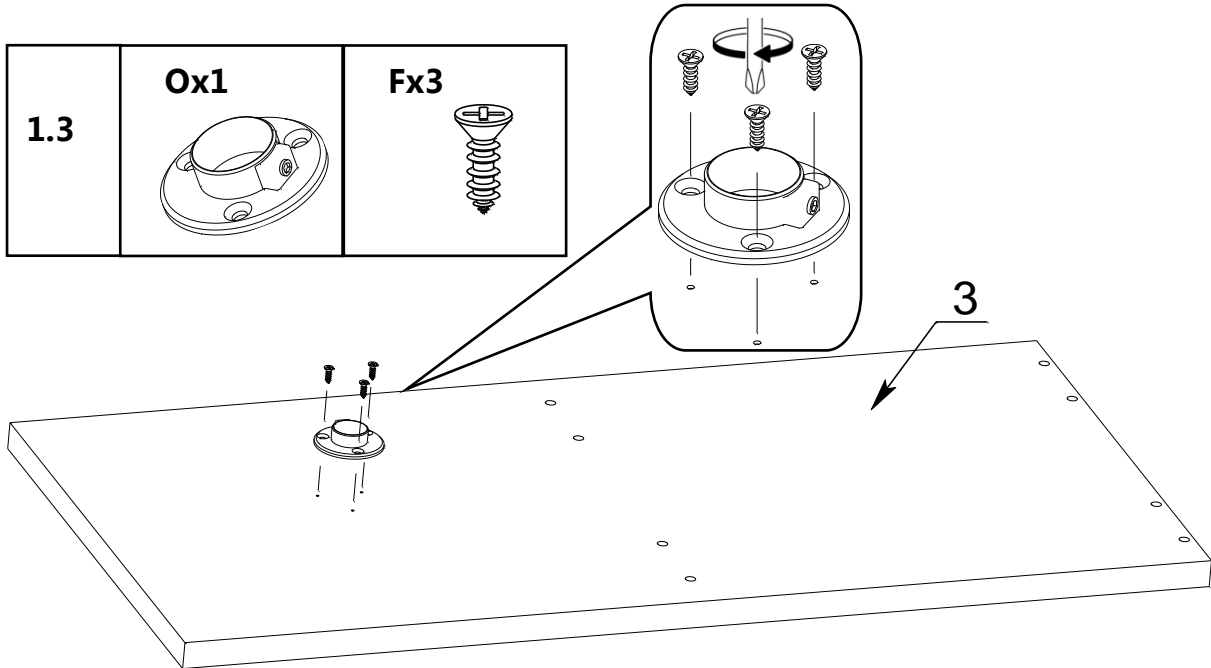
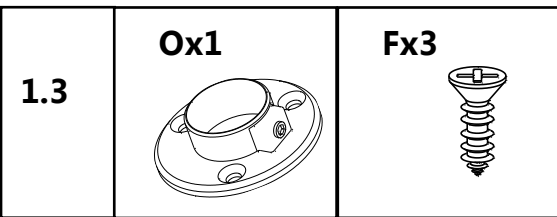
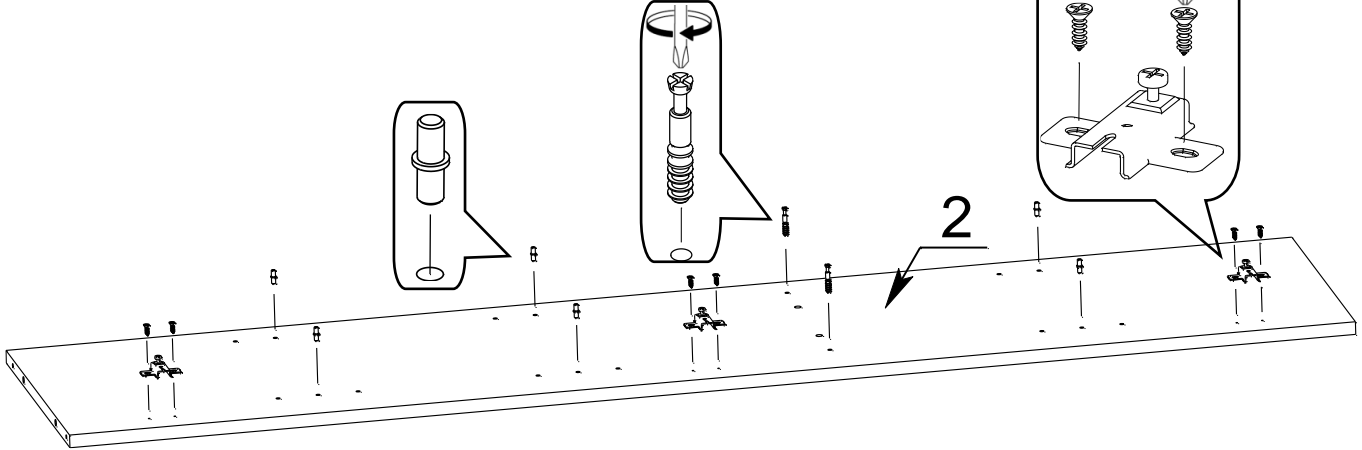
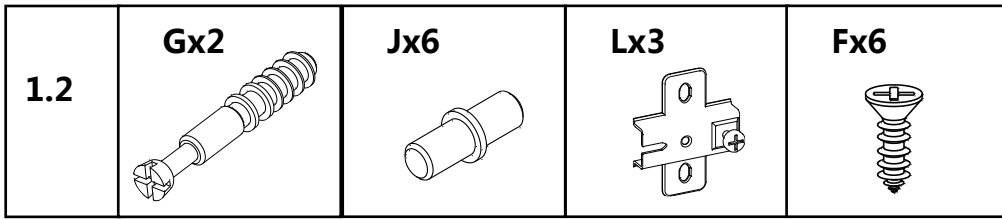
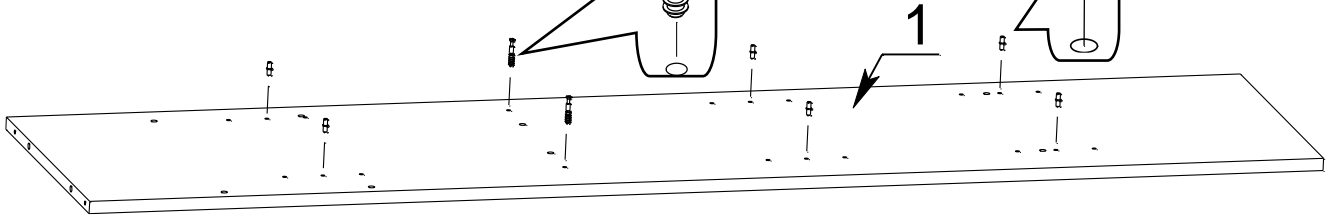
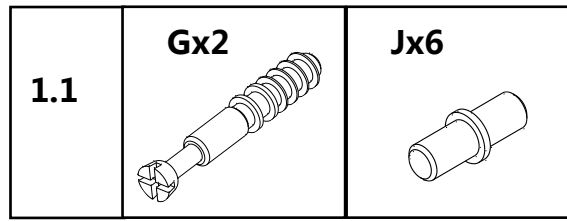

### Комплектность изделия (Шкаф для книг 1)

№ п/п	Наименование деталей	Размер	Кол-во
1	Стенка боковая правая	1608×380×16	1
2	Стенка боковая левая	1608×380×16	1
3	Стенка горизонтальный	840×400×22	1
4	Стенка горизонтальный	420×400×22	1
5	Щит горизонтальный	388×350×16	1
6	Полка	384×350×16	3
7	Дверка левая	1600×418×16	1
8	ДВП Стенка задняя	1650×418×3,2	1

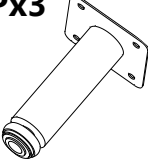
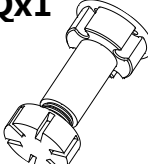
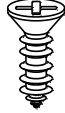

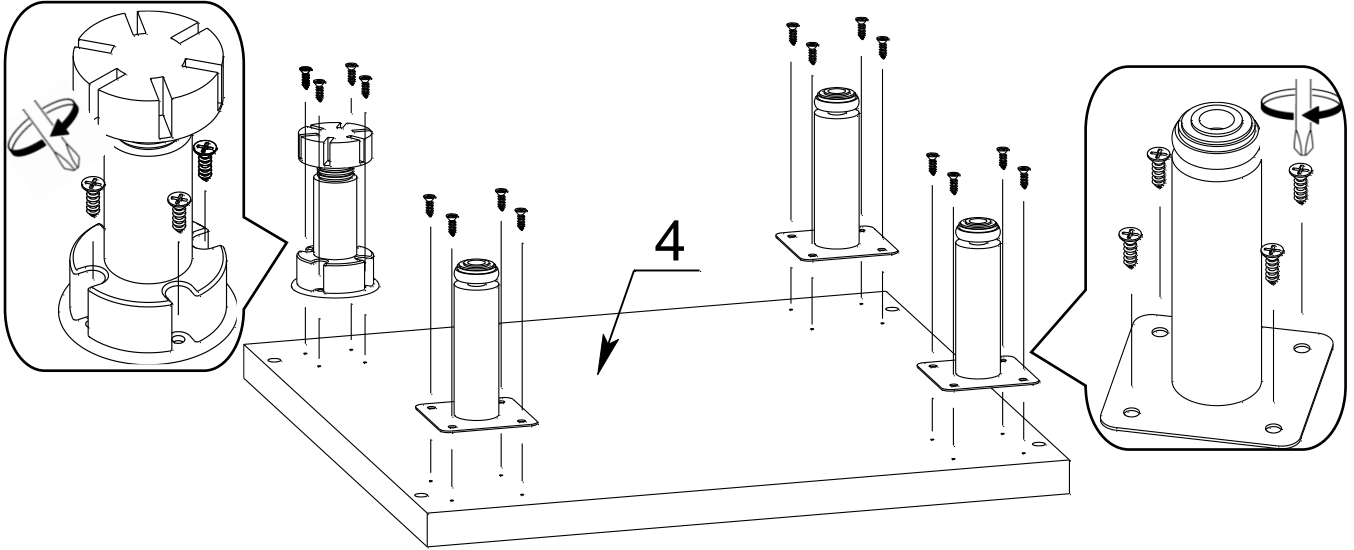
1.4	<b>Px3</b> 	<b>Qx1</b> 	<b>Fx16</b> 
-----	---	---	--

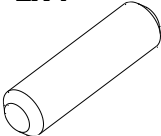

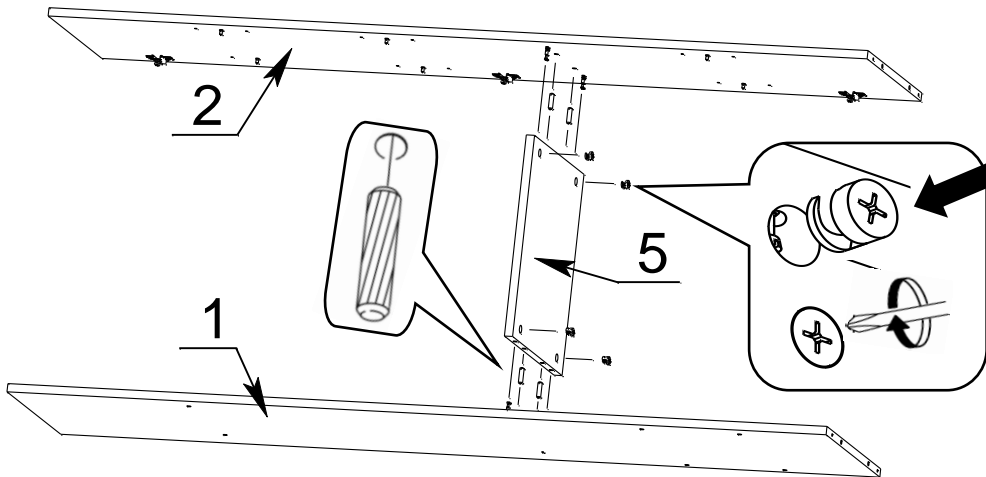

1.5	<b>Ex4</b> 	<b>Hx4</b> 
-----	---	---

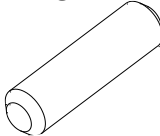
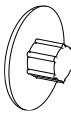

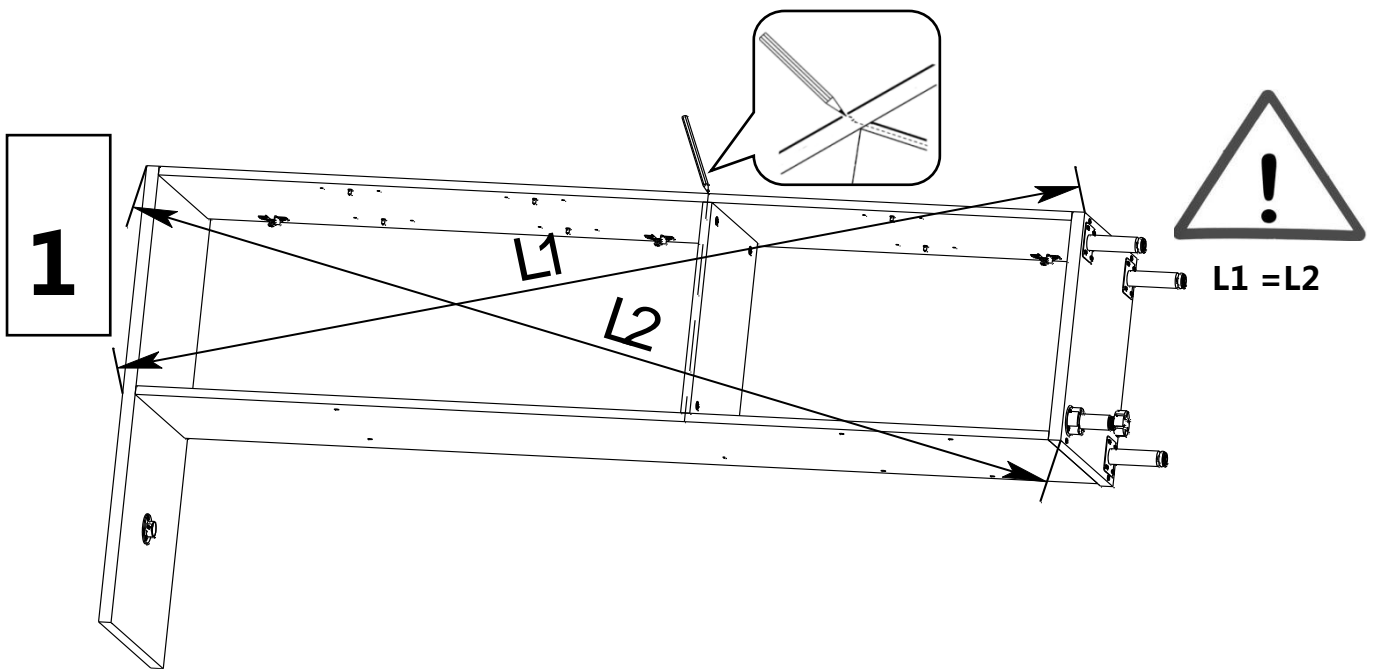
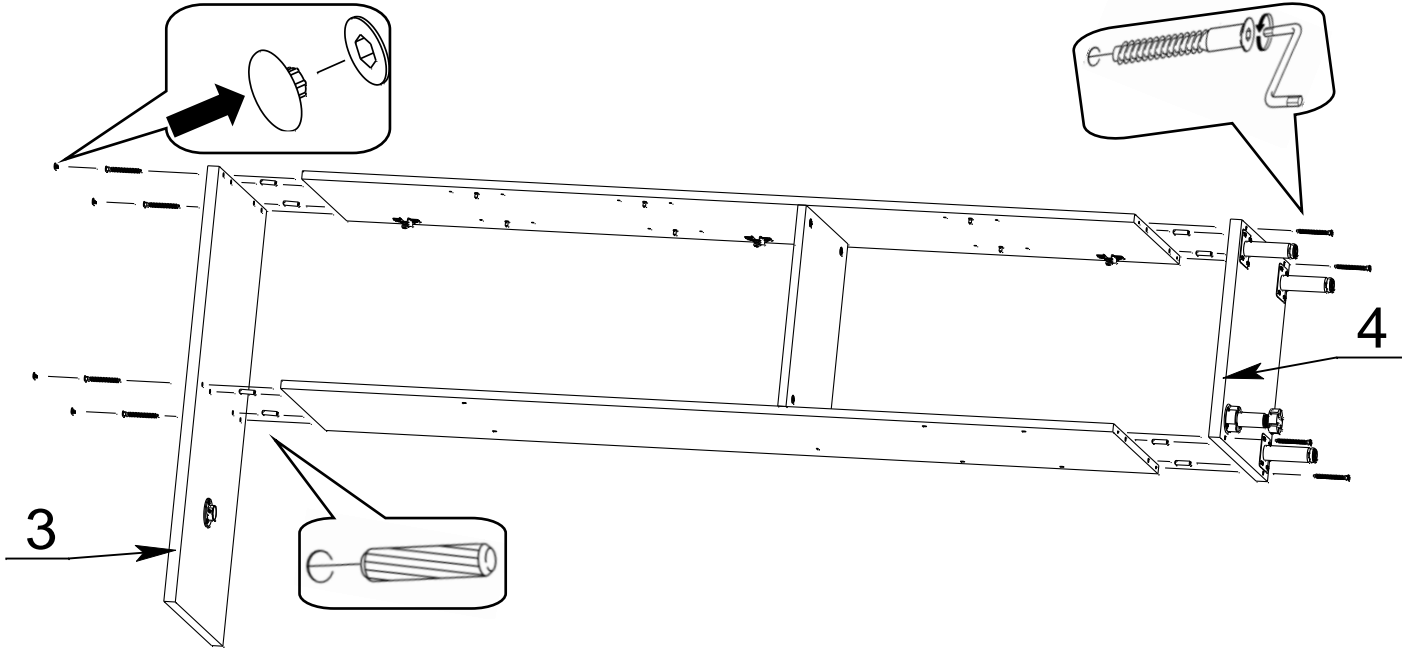
1.6	<b>Bx8</b> 	<b>Ex8</b> 	<b>Dx4</b> 
-----	---	---	---

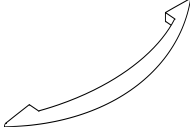

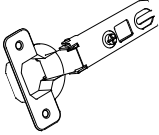
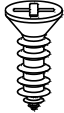
1.9	Mx1 	Nx2 	Kx3 	Fx6 
-----	--	--	--	---

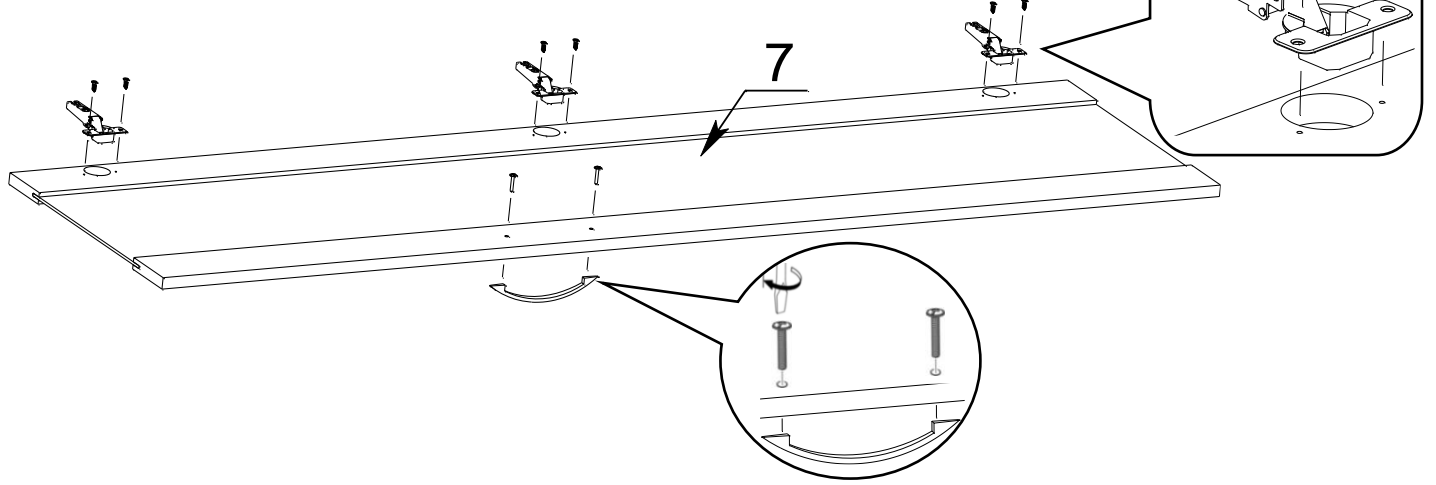

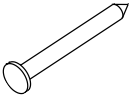
1.8	Wx33 
-----	---

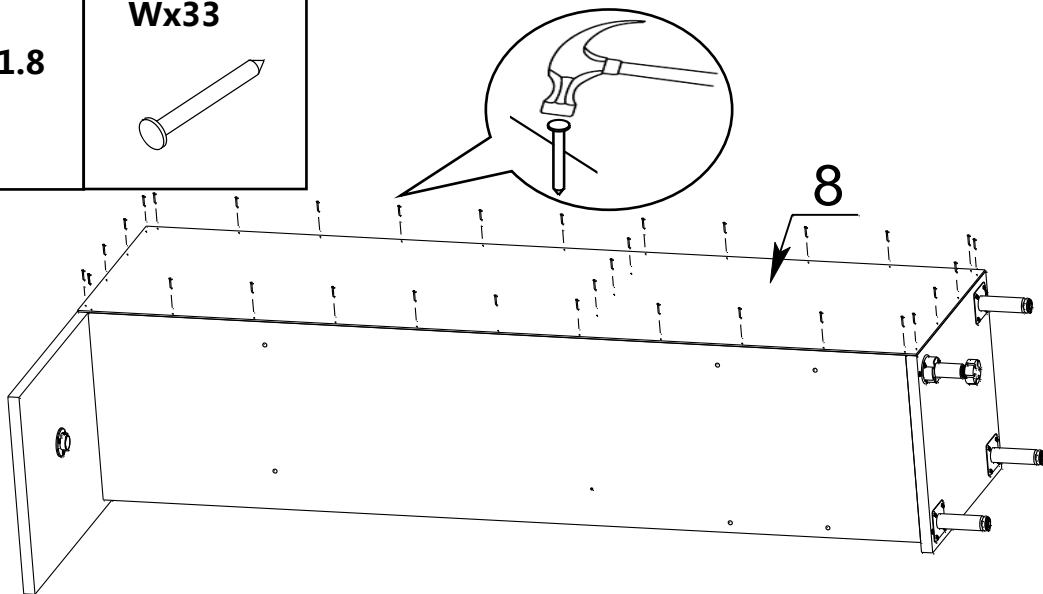



## 2. Комод

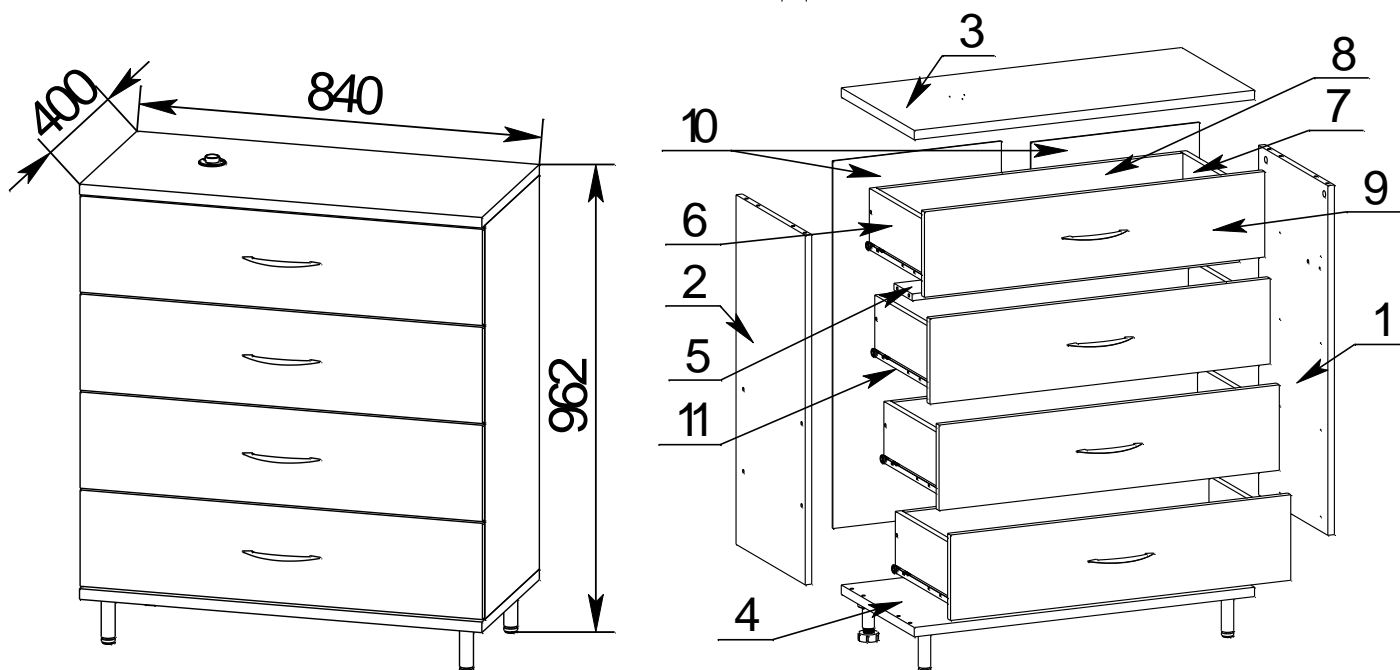

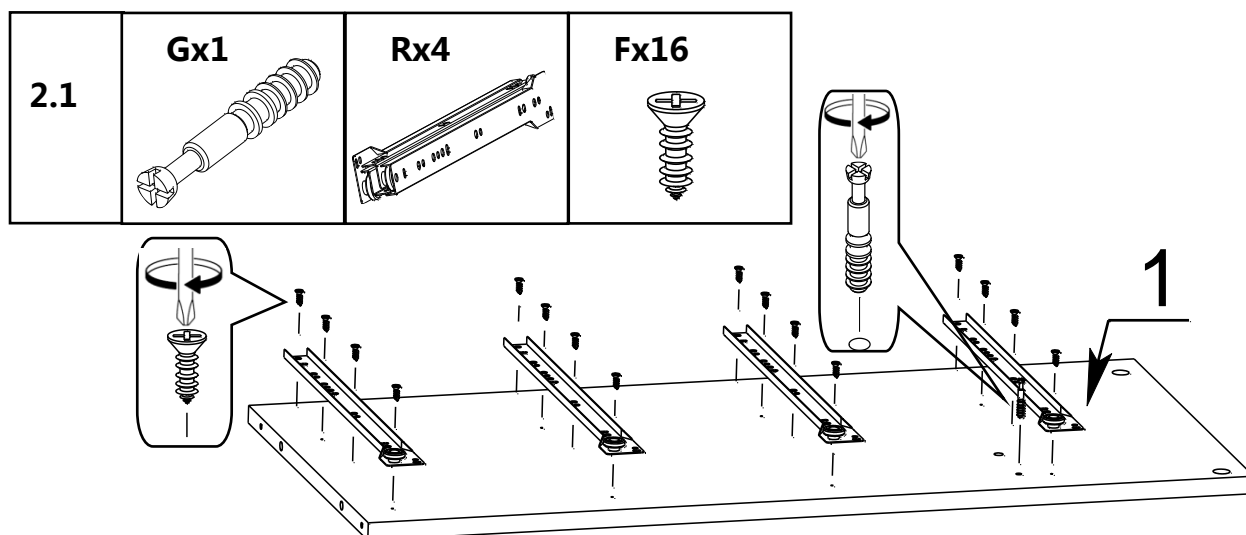

### Комплектность изделия (Комод)

№ п/п	Наименование деталей	Размер	Кол-во
1	Стенка боковая правая	818×380×16	1
2	Стенка боковая левая	818×380×16	1
3	Стенка горизонтальный	840×400×22	1
4	Стенка горизонтальный	840×400×22	1
5	Щит стяжной	808×100×16	1
6	Стенка боковая ящика левая	350×140×16	4
7	Стенка боковая ящика правая	350×140×16	4
8	Стенка задняя ящика	751×140×16	4
9	Накладка ящика	200×840×16	4
10	Стенка задняя (ДВП)	860×416×3,2	2
11	Дно ящика (ДВП)	783×355×3,2	4

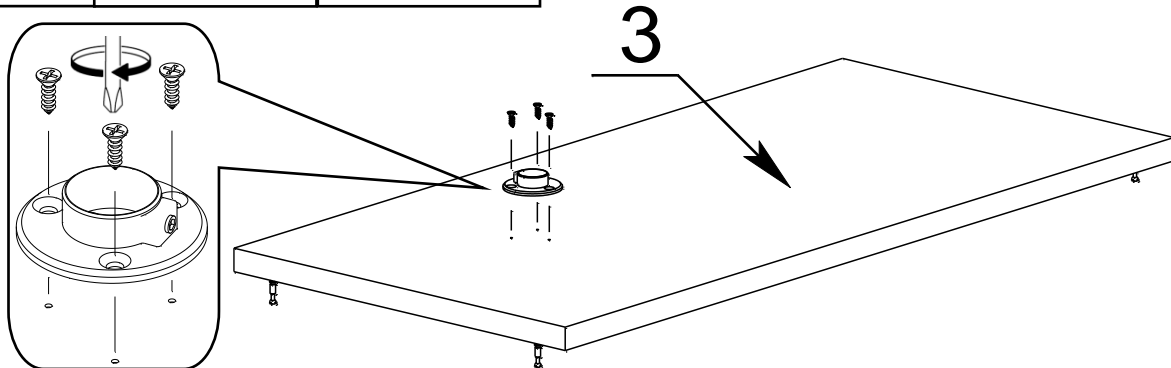
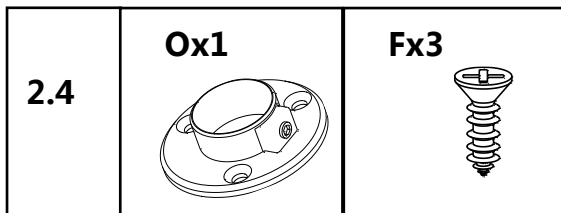
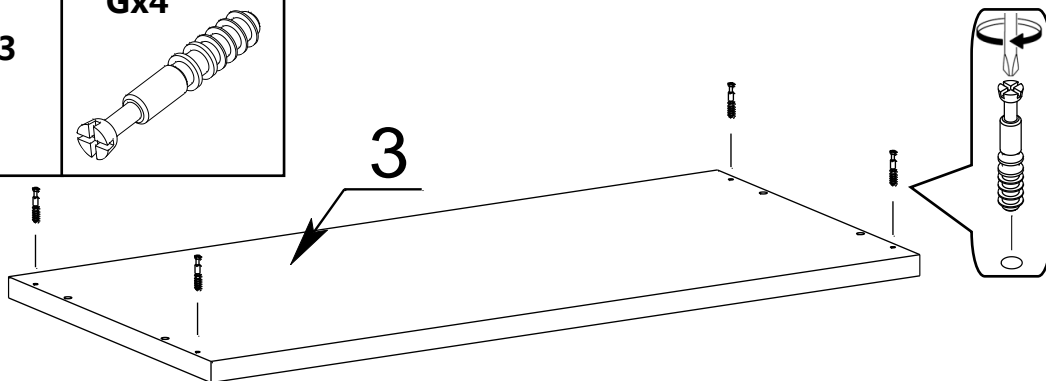
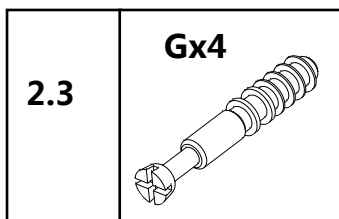
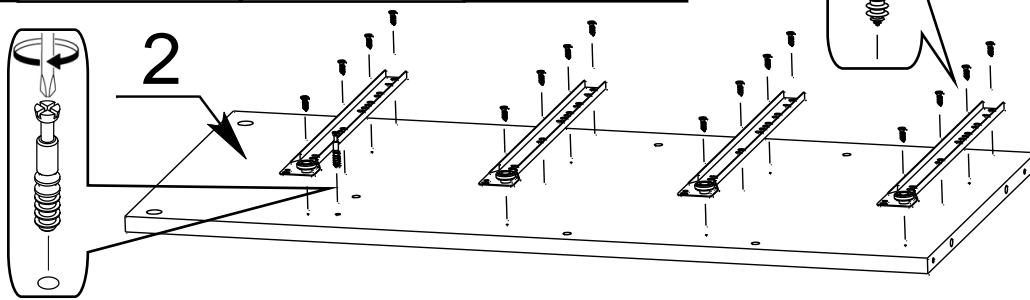
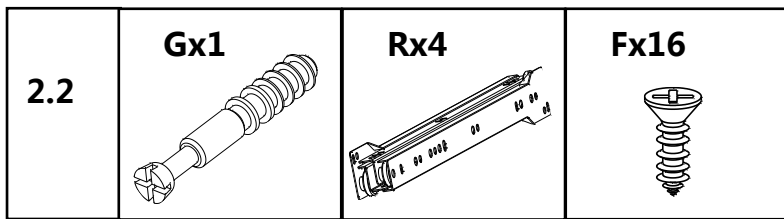

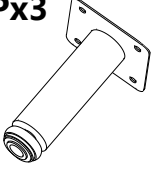
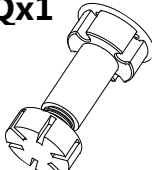

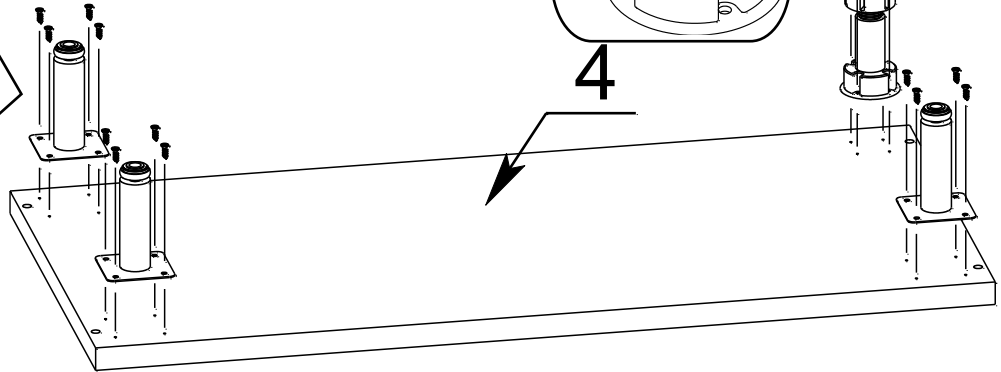
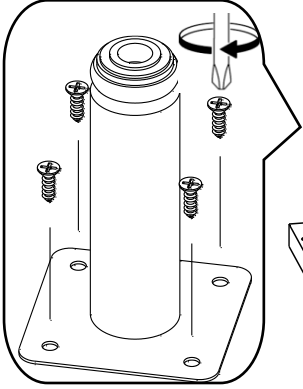
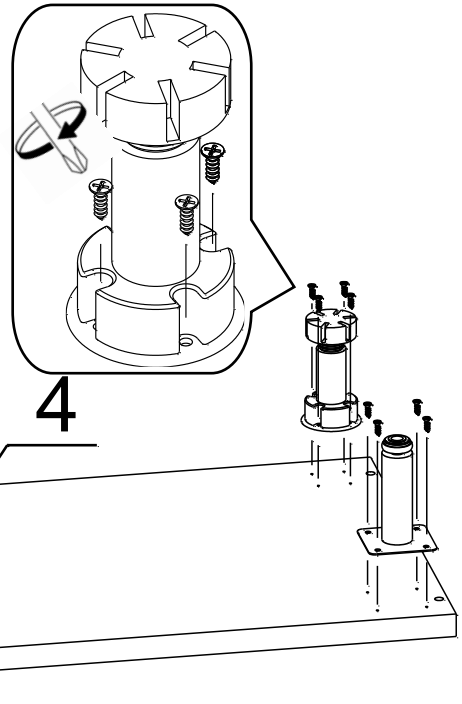

2.5	Px3 	Qx1 	Fx16 
-----	--	--	---

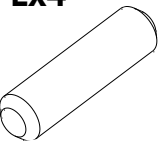
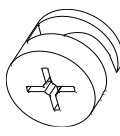

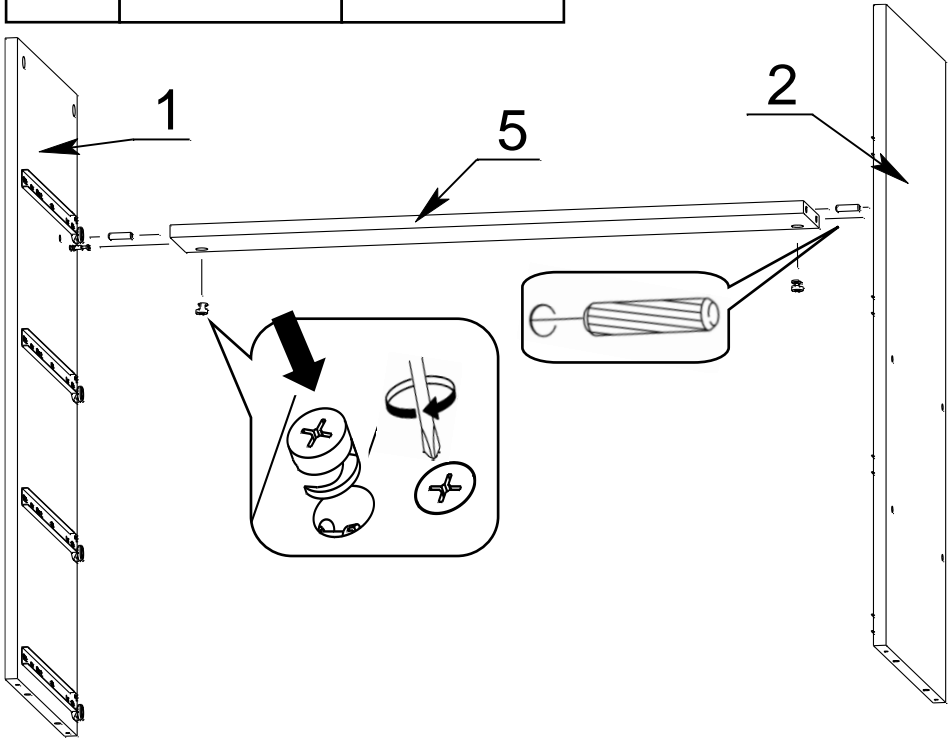
2.6	Ex4 	Hx4 
-----	--	--

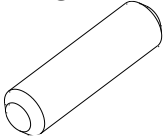
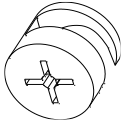

2.7	<b>Ex8</b> 	<b>Hx4</b> 	<b>Bx4</b> 
-----	---	---	---

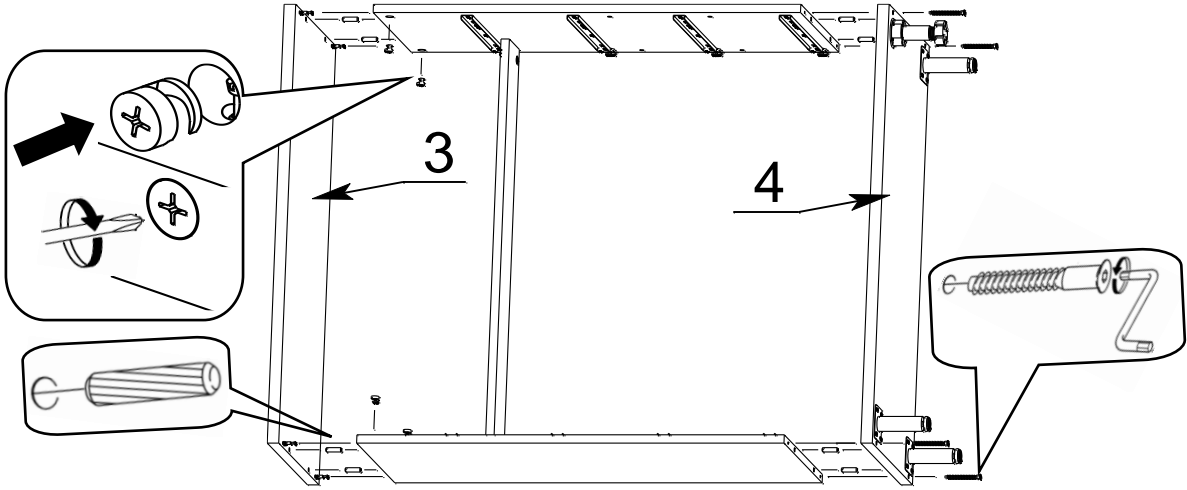

**2.**

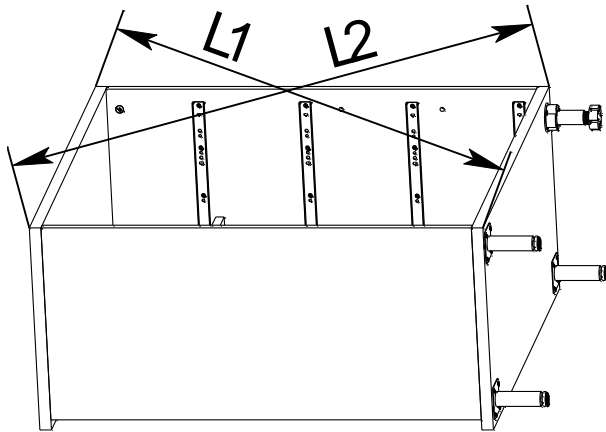

**11 -**

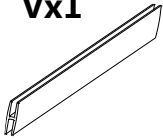
2.9	<b>Vx1</b> 
-----	---

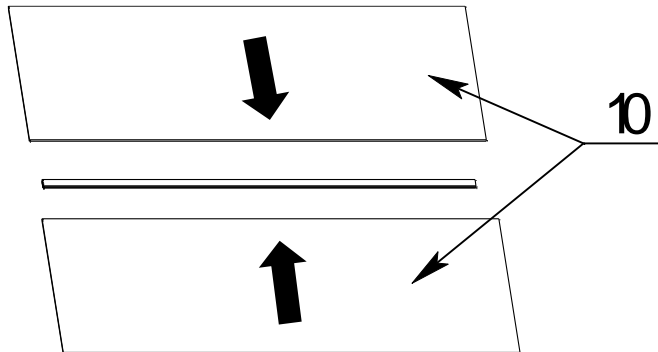

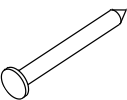
2.10	<b>Wx32</b> 
------	--

10

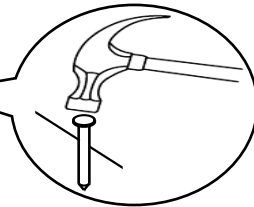
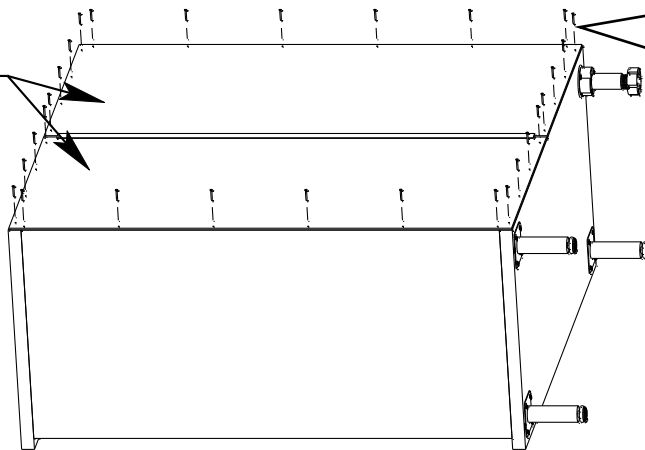

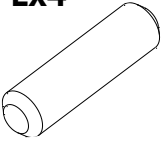
2.11	<b>Ax2</b> 	<b>Ex4</b> 
------	---	---

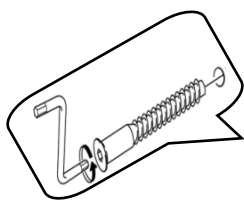

8

7



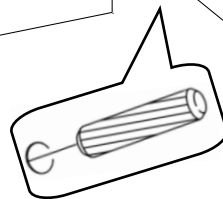
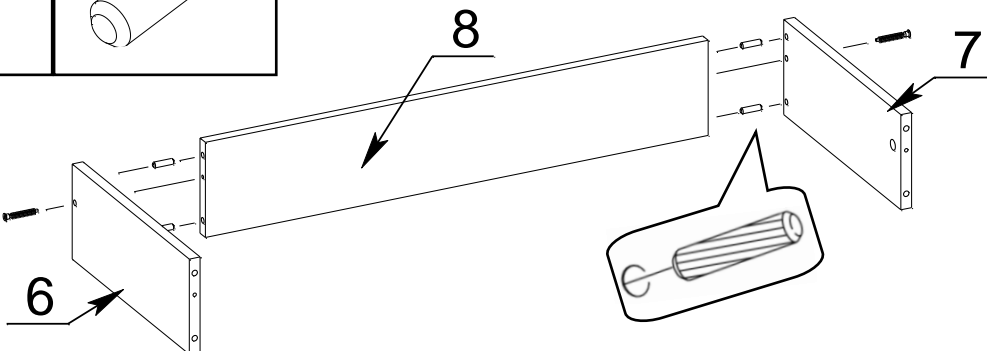

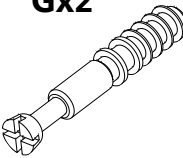
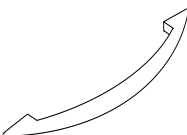
6



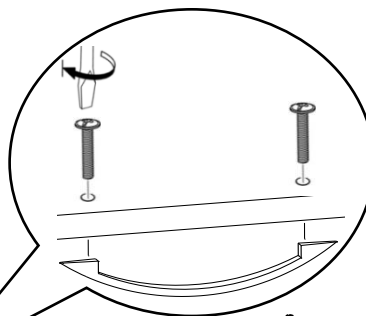
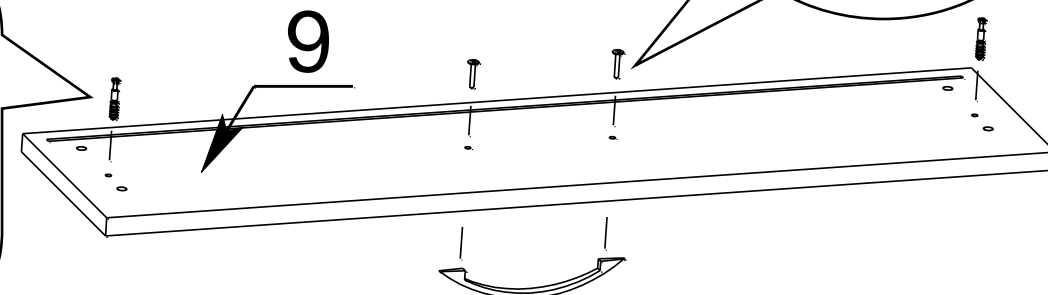
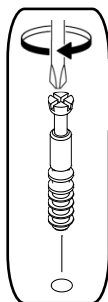

2.12	<b>Gx2</b> 	<b>Mx1</b> 	<b>Nx2</b> 
------	---	---	---

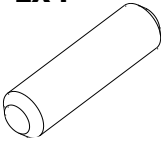
9

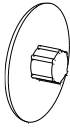

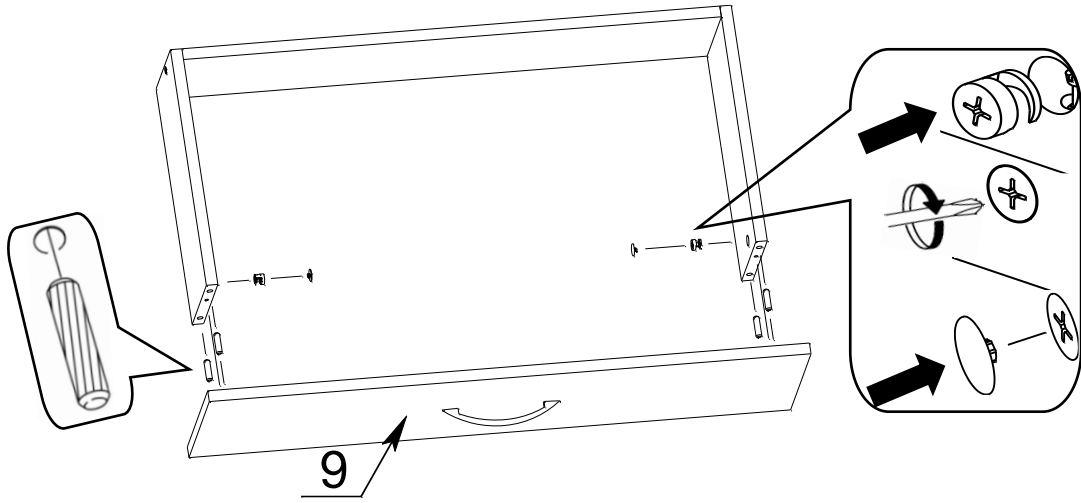
2.13	Ex4 	Hx2 	Ix2 
------	--	--	--



2.14	Yx12 
------	--

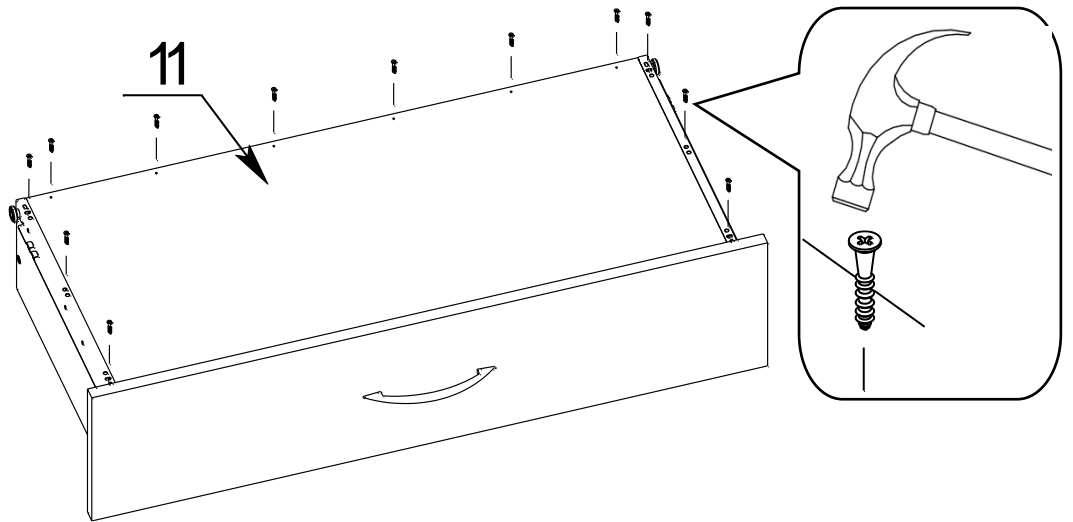

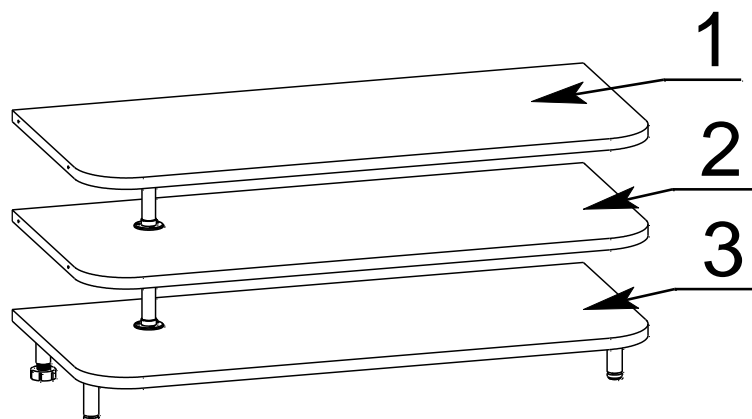

### 3. Сборка Тумба для телерадиоаппаратуры





*Комплектность изделия (Тумба для телерадиоаппаратуры)*

№ п/п	Наименование деталей	Размер	Кол-во
1	Щит горизонтальный	1100×500×22	1
2	Щит горизонтальный	1100×500×22	1
3	Щит горизонтальный	1100×500×22	1

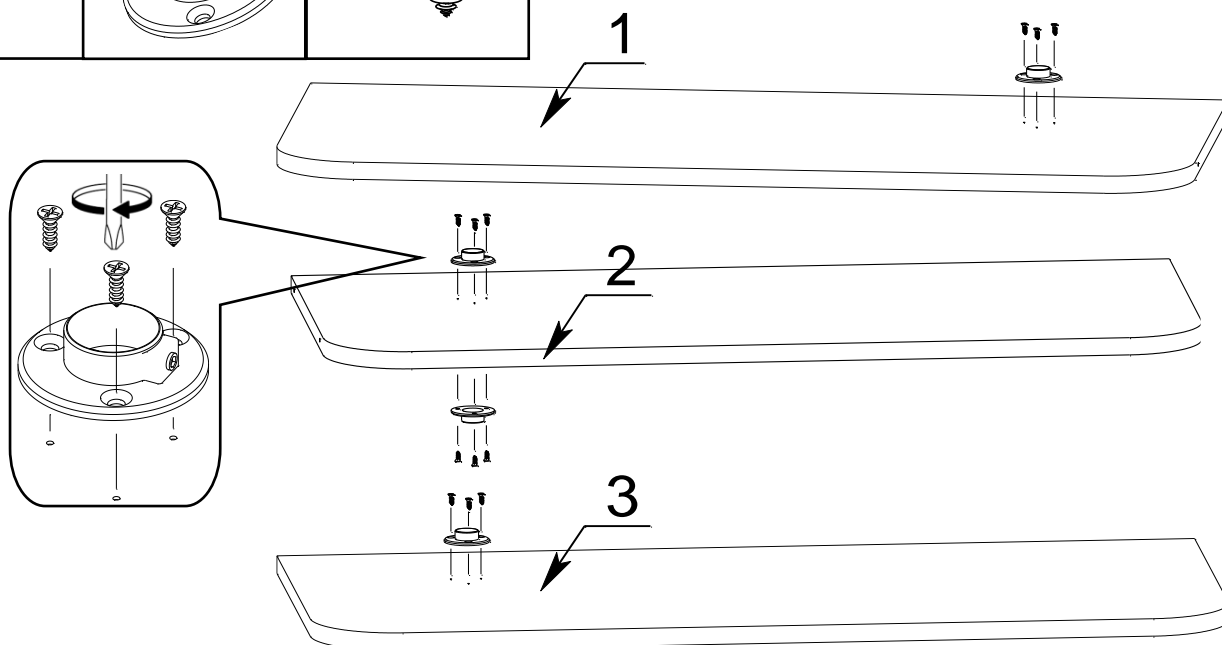
3.1	<b>Ox4</b>	<b>Fx12</b>
		

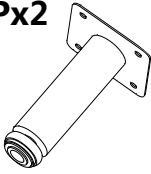
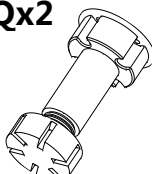

3.2	<b>Px2</b> 	<b>Qx2</b> 	<b>Fx16</b> 
-----	---	---	--

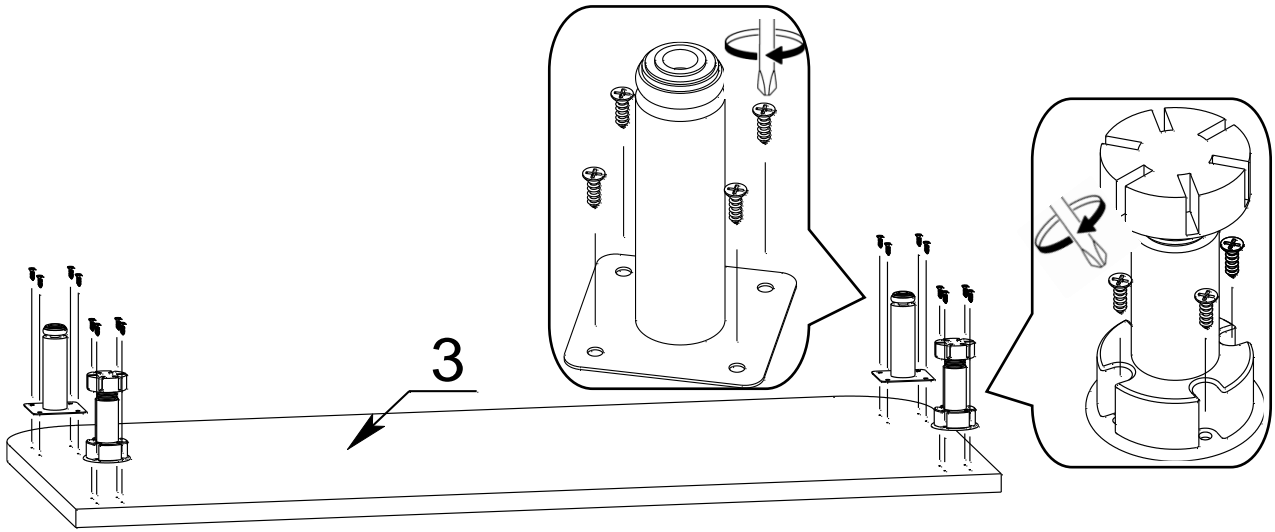

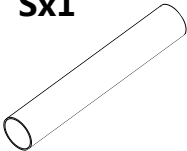
3.3	<b>Sx1</b> 
-----	--

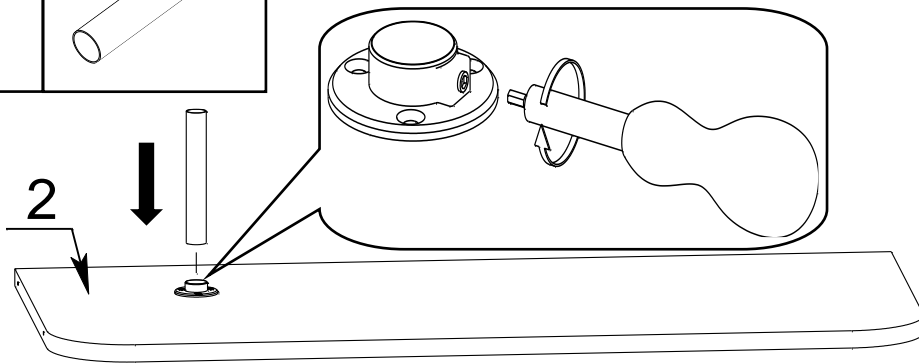

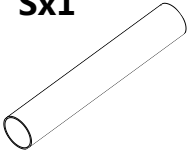
3.4	<b>Sx1</b> 
-----	---

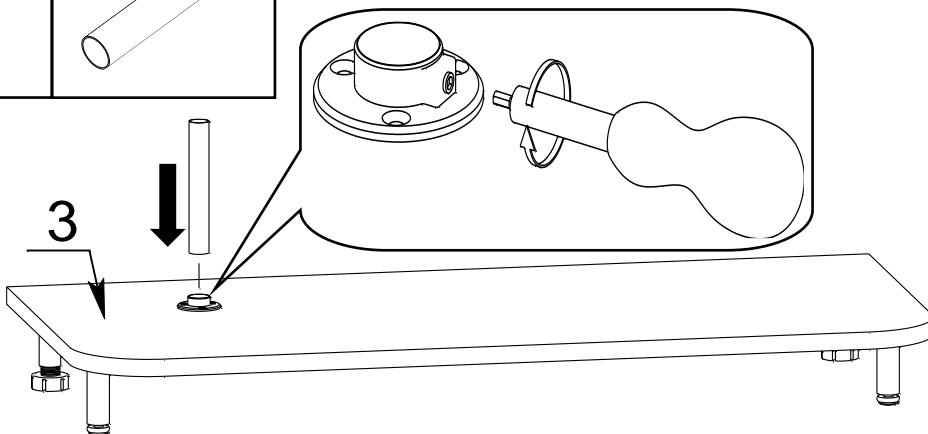



## 4. Сборка Полка

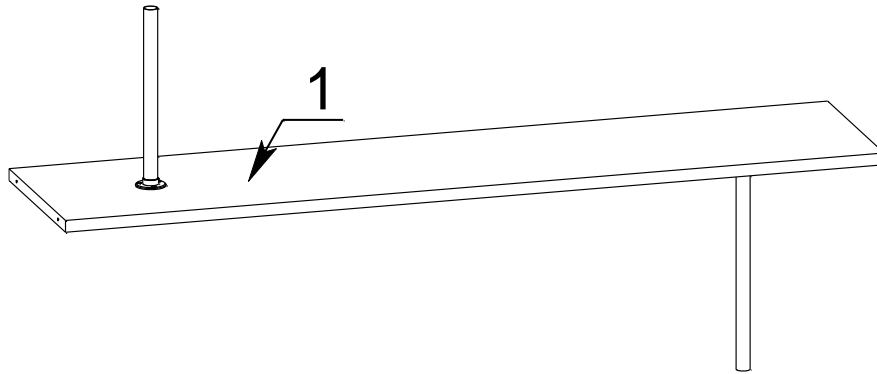

### Комплектность изделия (Полка)

№ п/п	Наименование деталей	Размер	Кол-во
1	Щит горизонтальный	1520×350×22	1

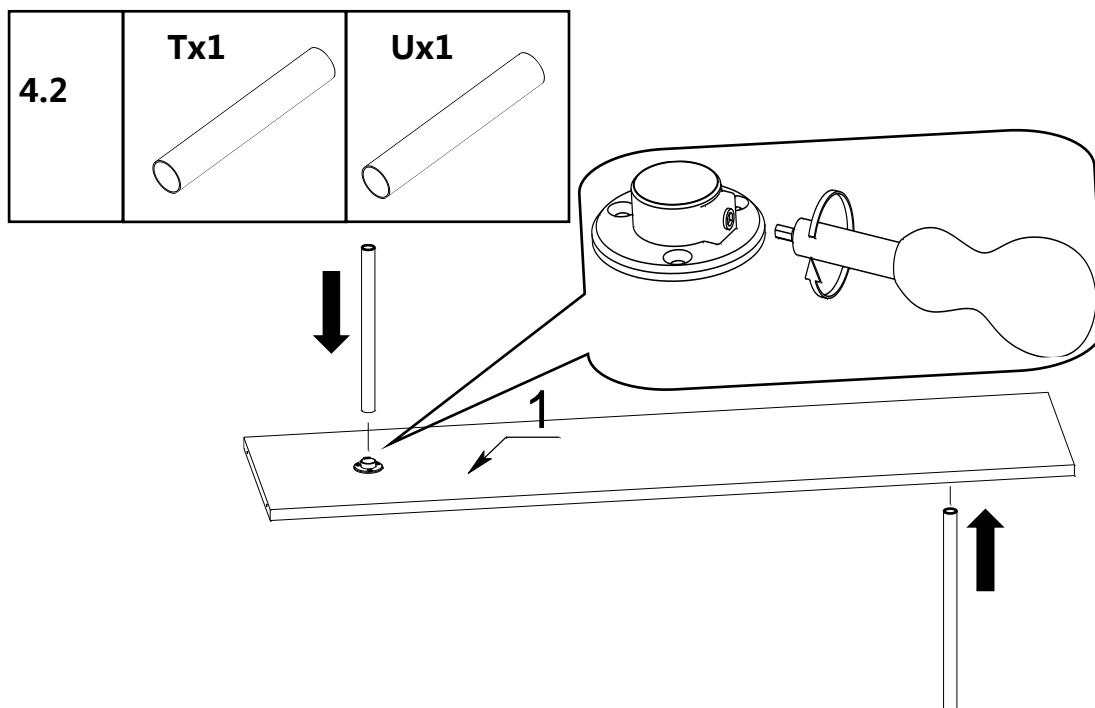
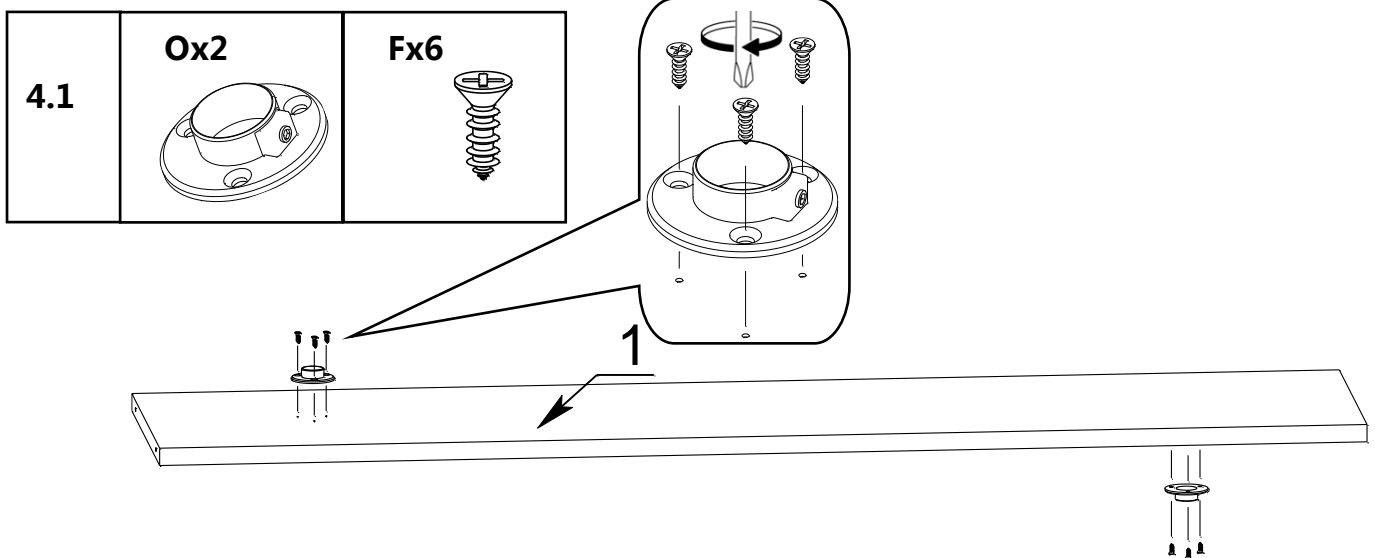

## 5. Сборка Набора «Грация-03»

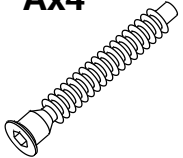
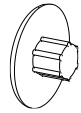
5.1	Ax4 	Dx2 
-----	--	--

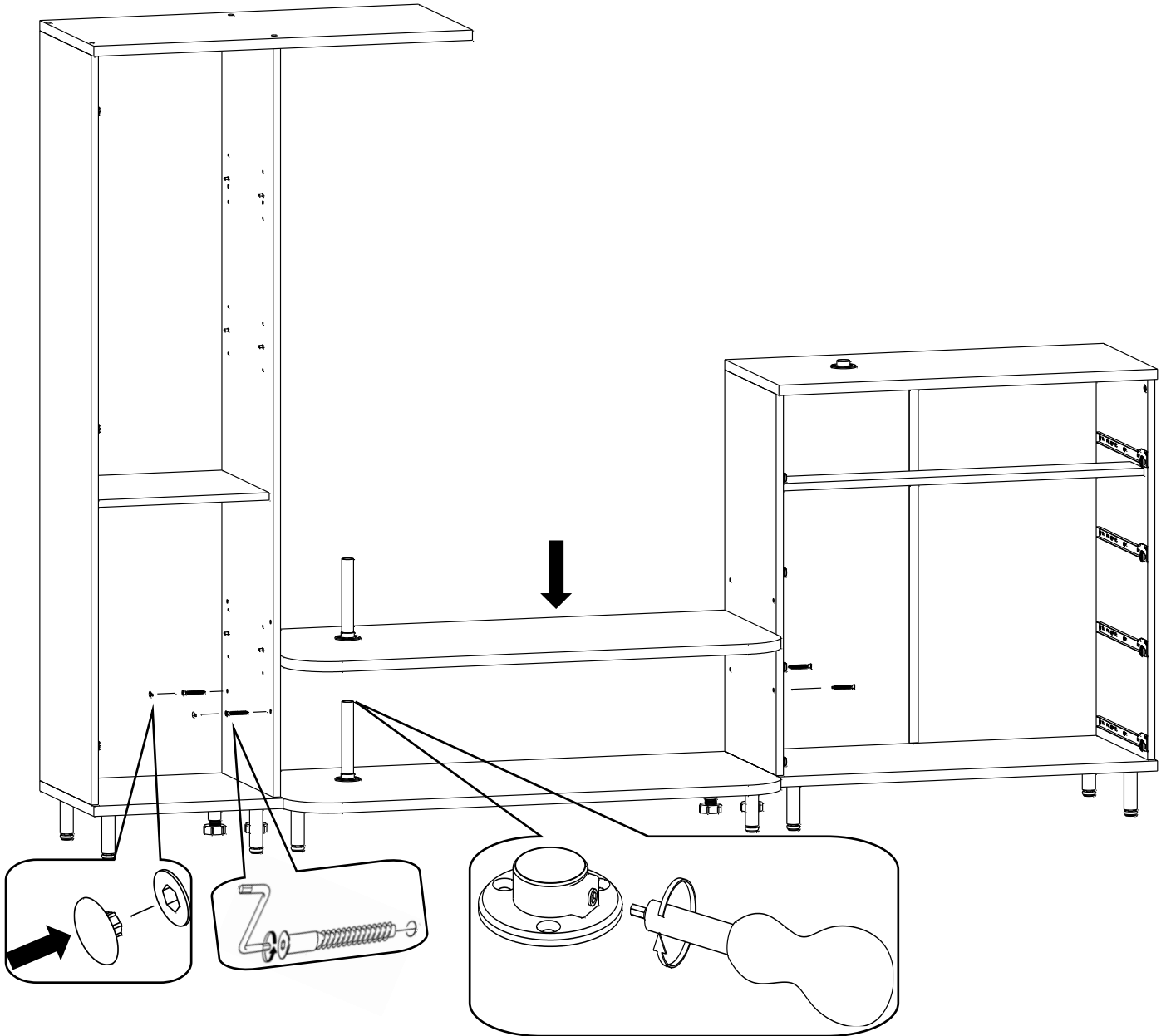

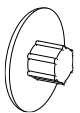
5.2	<b>Ax6</b> 	<b>Dx4</b> 
-----	---	---

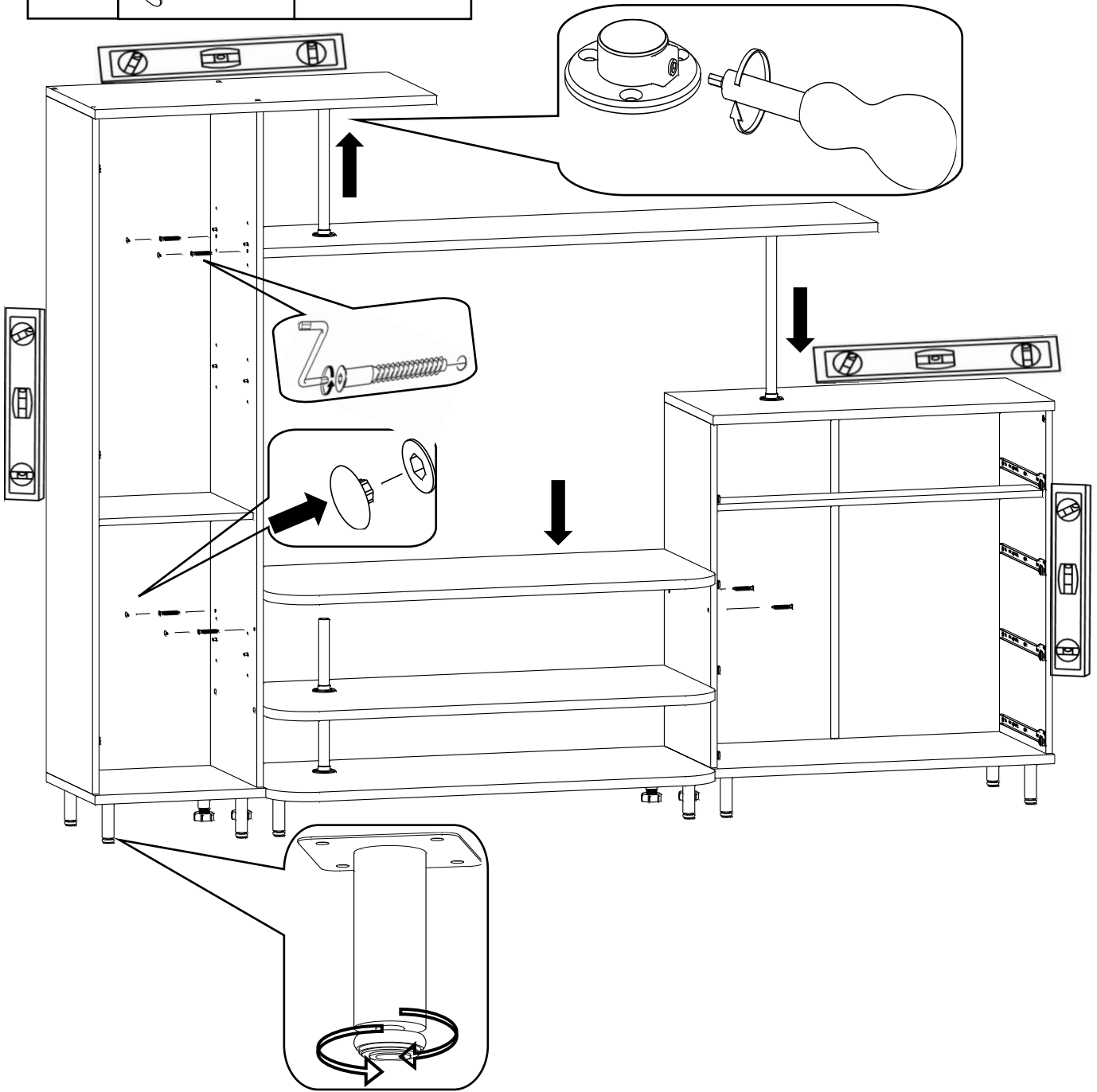

5.

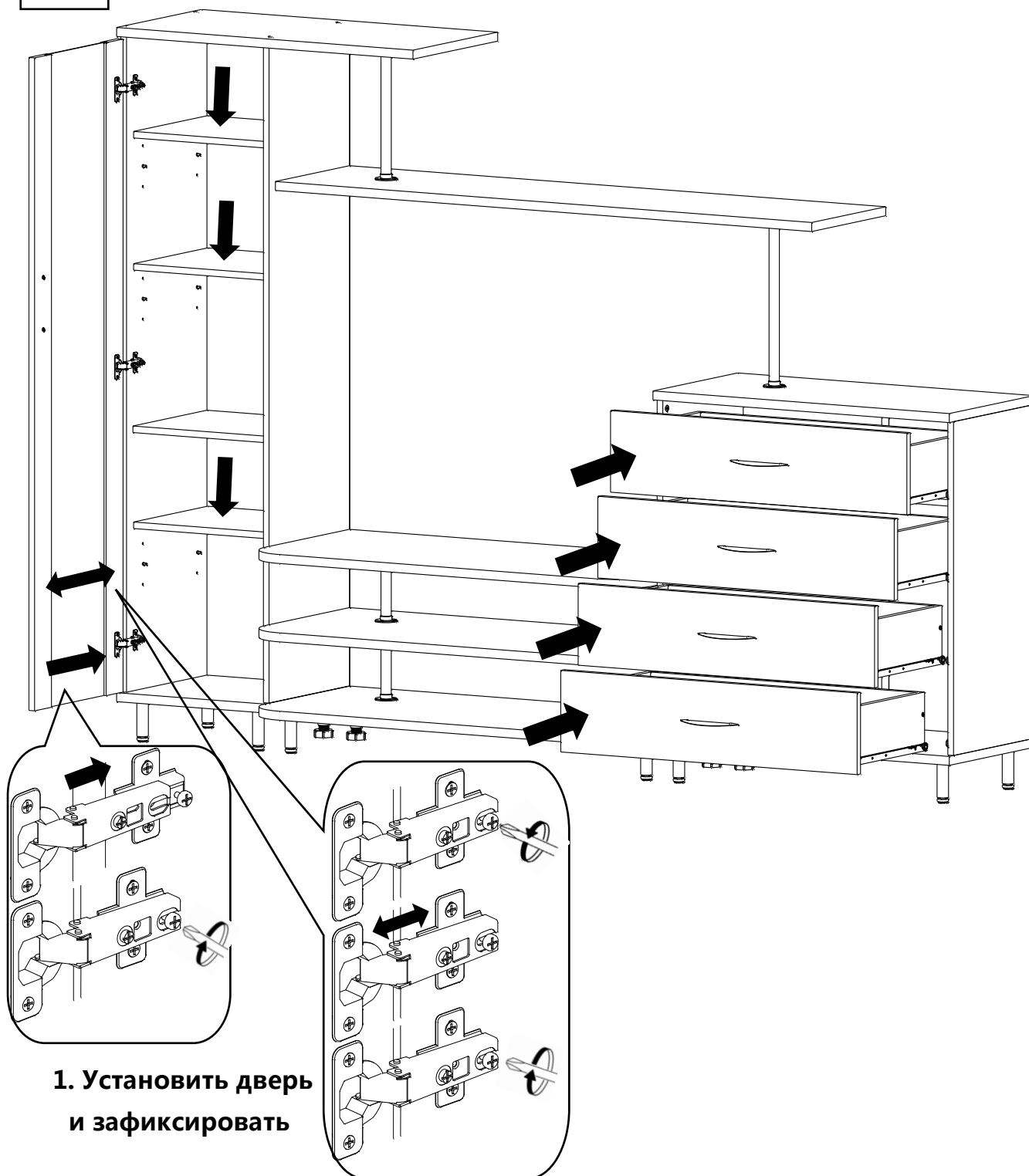

1. Установить дверь  
и зафиксировать

2. Регулировка по глубине

**5.**

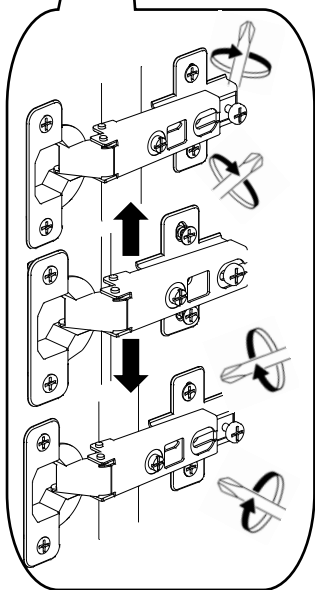
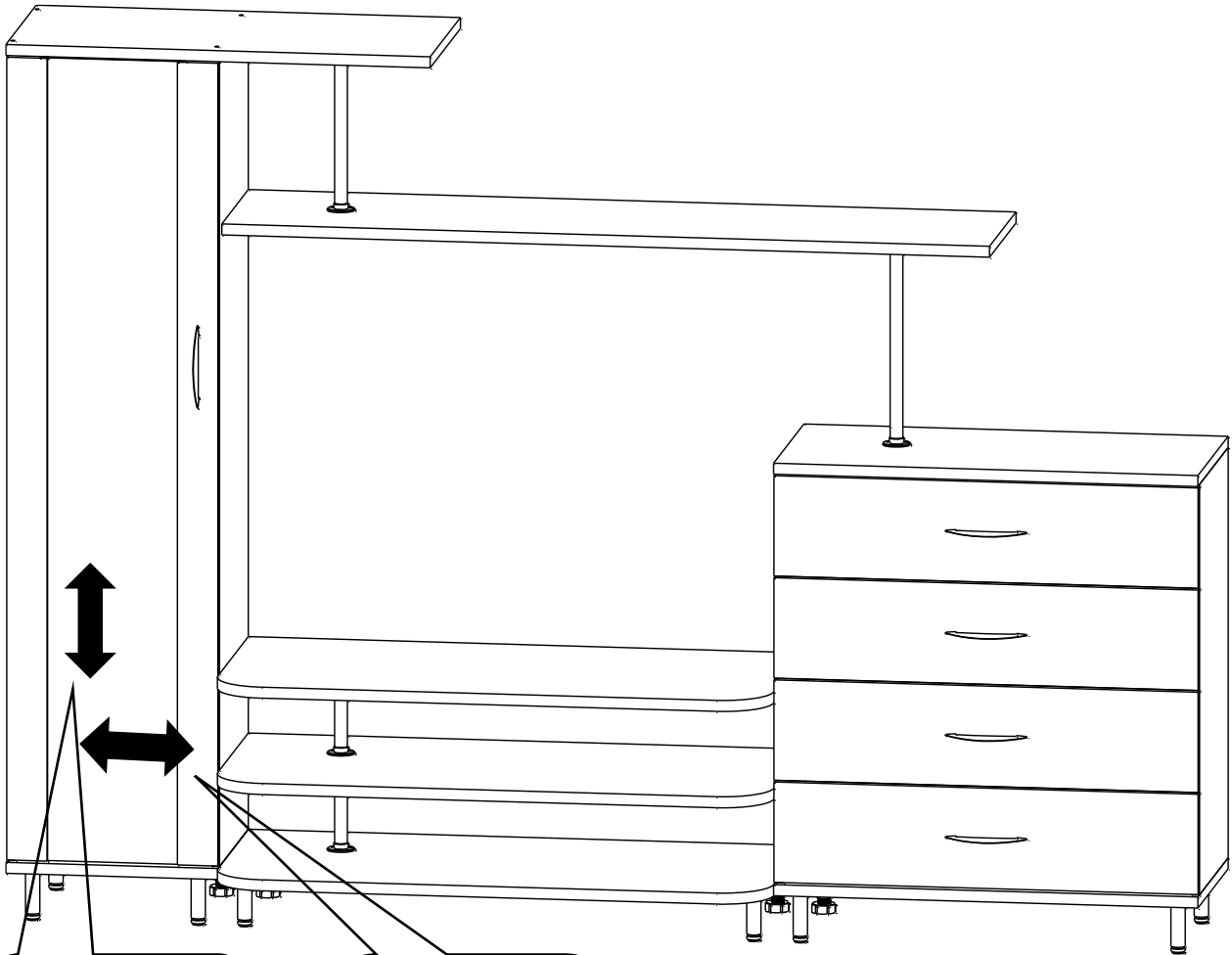

**3.**

**Регулировка  
по высоте**

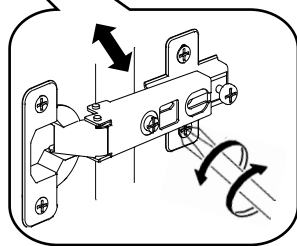

**4. Регулировка  
по ширине**

## **Рекомендации по обслуживанию.**

Сборка изделия должна производиться в порядке, изложенном в настоящем руководстве и вблизи места, где оно в дальнейшем будет установлено. В процессе эксплуатации изделий необходимо периодически затягивать ослабленные болтовые и винтовые соединения. В случае необходимости перемещения изделия по квартире перед его перестановкой, необходимо полностью освободить его от груза. Во избежание поломки имеющихся опор передвигать производить приподнимая изделие над уровнем пола. Рекомендуется перед перестановкой вынуть выдвижные ящики и вкладные полки. Удаление пыли с изделий следует производить слегка влажной салфеткой. Во избежание коробления деталей и изменения цвета изделия следует избегать установки мебели на прямых солнечных лучах.

Мебель рекомендуется эксплуатировать в помещениях при температуре не ниже +2°C и относительной влажности 45-70%. При эксплуатации изделий набора ЗАПРЕЩАЕТСЯ:

- устанавливать мебель вблизи отопительных приборов и вплотную к сырým стенам и в помещениях с относительной влажностью более 70%;
- в процессе сборки и эксплуатации изделий набора становиться ногами на заднюю стенку, и горизонтальные щиты (полки);
- перемещение изделия за верхний щит (крышку);
- применять химические чистящие средства для уборки мебели.

### **ГАРАНТИЯ ИЗГОТОВИТЕЛЯ:**

Гарантийный срок эксплуатации изделия - 24 месяца со дня продажи магазином. В период гарантийного срока изготовитель гарантирует ремонт изделий или их замену, если потребителем не нарушены правила эксплуатации.

Изделие соответствует требованиям ГОСТ 16371-93.

Срок службы мебели – 2 года.

Предприятие-изготовитель оставляет за собой право вносить изменения в конструкцию изделия, не ухудшая его конструктивные и эксплуатационные характеристики.

**Спасибо за покупку!!!**